

No part of this product may be reproduced in any form or by any electronic or mechanical means, including information storage and retrieval systems, without written permission from the IB.

Additionally, the license tied with this product prohibits commercial use of any selected files or extracts from this product. Use by third parties, including but not limited to publishers, private teachers, tutoring or study services, preparatory schools, vendors operating curriculum mapping services or teacher resource digital platforms and app developers, is not permitted and is subject to the IB's prior written consent via a license. More information on how to request a license can be obtained from <https://ibo.org/become-an-ib-school/ib-publishing/licensing/applying-for-a-license/>.

Aucune partie de ce produit ne peut être reproduite sous quelque forme ni par quelque moyen que ce soit, électronique ou mécanique, y compris des systèmes de stockage et de récupération d'informations, sans l'autorisation écrite de l'IB.

De plus, la licence associée à ce produit interdit toute utilisation commerciale de tout fichier ou extrait sélectionné dans ce produit. L'utilisation par des tiers, y compris, sans toutefois s'y limiter, des éditeurs, des professeurs particuliers, des services de tutorat ou d'aide aux études, des établissements de préparation à l'enseignement supérieur, des fournisseurs de services de planification des programmes d'études, des gestionnaires de plateformes pédagogiques en ligne, et des développeurs d'applications, n'est pas autorisée et est soumise au consentement écrit préalable de l'IB par l'intermédiaire d'une licence. Pour plus d'informations sur la procédure à suivre pour demander une licence, rendez-vous à l'adresse suivante : <https://ibo.org/become-an-ib-school/ib-publishing/licensing/applying-for-a-license/>.

No se podrá reproducir ninguna parte de este producto de ninguna forma ni por ningún medio electrónico o mecánico, incluidos los sistemas de almacenamiento y recuperación de información, sin que medie la autorización escrita del IB.

Además, la licencia vinculada a este producto prohíbe el uso con fines comerciales de todo archivo o fragmento seleccionado de este producto. El uso por parte de terceros —lo que incluye, a título enunciativo, editoriales, profesores particulares, servicios de apoyo académico o ayuda para el estudio, colegios preparatorios, desarrolladores de aplicaciones y entidades que presten servicios de planificación curricular u ofrezcan recursos para docentes mediante plataformas digitales— no está permitido y estará sujeto al otorgamiento previo de una licencia escrita por parte del IB. En este enlace encontrará más información sobre cómo solicitar una licencia: <https://ibo.org/become-an-ib-school/ib-publishing/licensing/applying-for-a-license/>.

Biology
Standard level
Paper 3

Thursday 12 November 2020 (morning)

Candidate session number

--	--	--	--	--	--	--	--	--	--	--

1 hour

Instructions to candidates

- Write your session number in the boxes above.
- Do not open this examination paper until instructed to do so.
- Answers must be written within the answer boxes provided.
- A calculator is required for this paper.
- The maximum mark for this examination paper is **[35 marks]**.

Section A	Questions
Answer all questions.	1 – 3

Section B	Questions
Answer all of the questions from one of the options.	
Option A — Neurobiology and behaviour	4 – 7
Option B — Biotechnology and bioinformatics	8 – 11
Option C — Ecology and conservation	12 – 15
Option D — Human physiology	16 – 19



Please **do not** write on this page.

Answers written on this page
will not be marked.



32EP02

Section A

Answer **all** questions. Answers must be written within the answer boxes provided.

1. A nomogram can be used to determine the body mass index (BMI) of an individual.

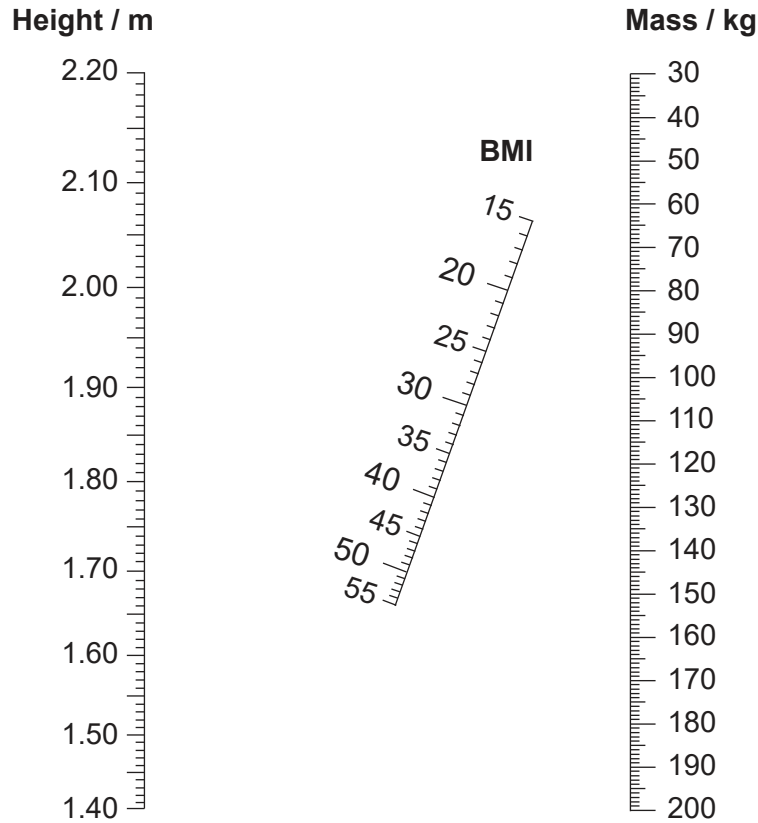

(a) State the BMI of a person of mass 80 kg and 1.80 m in height. [1]

.....

(b) Explain how measurement of BMI could help to assess whether a person has an increased risk of type II diabetes. [2]

.....
.....
.....
.....
.....



32EP03

Turn over

2. In an investigation to compare the elasticity of arteries and veins, rings of the same diameter (20 mm) of artery and vein tissue were cut from blood vessels obtained from a mammal.

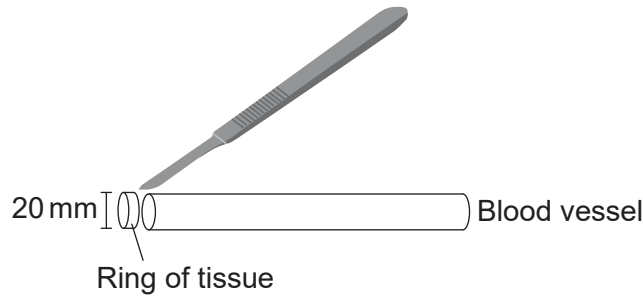

Each ring was attached to a clamp. Multiple masses of 10 g were added and removed. The vertical diameter of the artery and the vein was measured, both with the mass and once the mass had been removed.

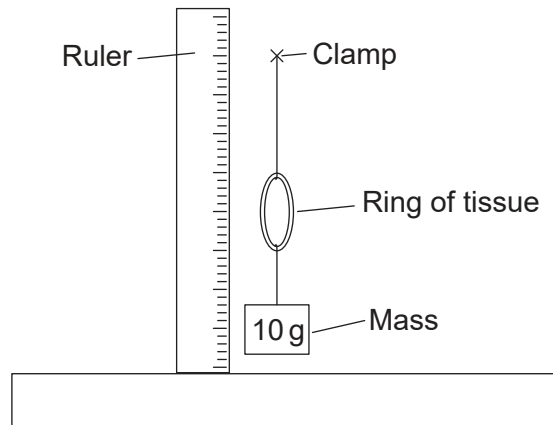

The results are shown in the table.

Mass / g	Diameter of vein / mm		Diameter of artery / mm	
	With mass	Mass removed	With mass	Mass removed
0	20	20	20	20
10	26	26	26	22
20	34	33	30	23
30	38	36	35	23
40	40	37	38	24

- (a) State the independent and dependent variables in this experiment. [2]

Independent:

Dependent:

(This question continues on the following page)



(Question 2 continued)

(b) State **one** feature of the rings that has to be kept constant apart from their initial diameter. [1]

.....
.....

(c) Explain the differences between the results shown for vein and artery. [3]

.....
.....
.....
.....
.....



32EP05

Turn over

3. To investigate whether carbon dioxide is required for photosynthesis, a plant was irrigated using water from which carbon dioxide had been removed and was then placed in the apparatus shown in the diagram. The apparatus was left in darkness for 24 hours to destarch the leaves. Then, after several hours in light, a leaf was removed from the plant and found to contain no starch when tested. A control was performed using a second plant. A leaf from this plant tested positive for starch.

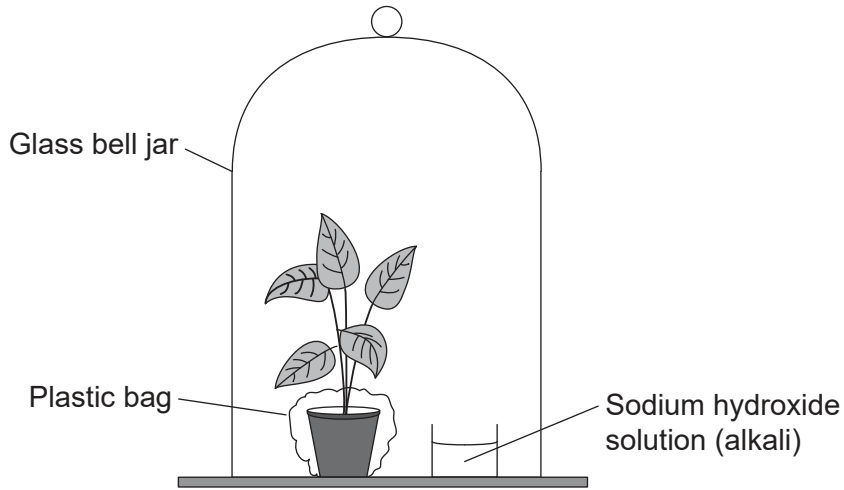

- (a) Describe the control for this experiment. [2]

.....

.....

.....

.....

- (b) Outline how the carbon dioxide could be removed from the water used to irrigate the plant. [1]

.....

.....

(This question continues on the following page)



(Question 3 continued)

- (c) Suggest how a plastic bag placed around the plant pot prevents carbon dioxide from reaching the plant's leaves. [1]

.....

.....

.....

.....

- (d) A chromatograph was made of the photosynthetic pigments of a leaf of the plant.

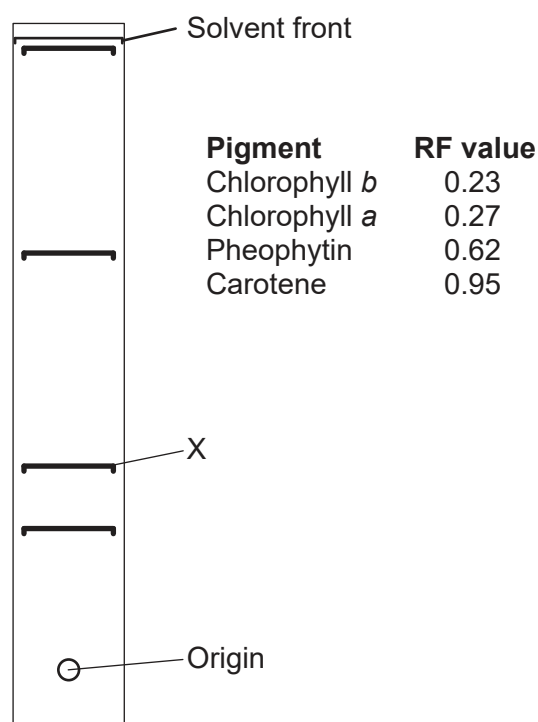

Outline what measurements would be taken to identify pigment X. [2]

.....

.....

.....

.....



32EP07

Turn over

Section B

Answer **all** of the questions from **one** of the options. Answers must be written within the answer boxes provided.

Option A — Neurobiology and behaviour

4.

Removed for copyright reasons

(a)

(b)

(Option A continues on the following page)



32EP08

(Option A, question 4 continued)

(c)

Removed for copyright reasons

(Option A continues on the following page)



32EP09

Turn over

(Option A continued)

5. The diagram shows rays of light entering the eyes from point Q in the right visual field.

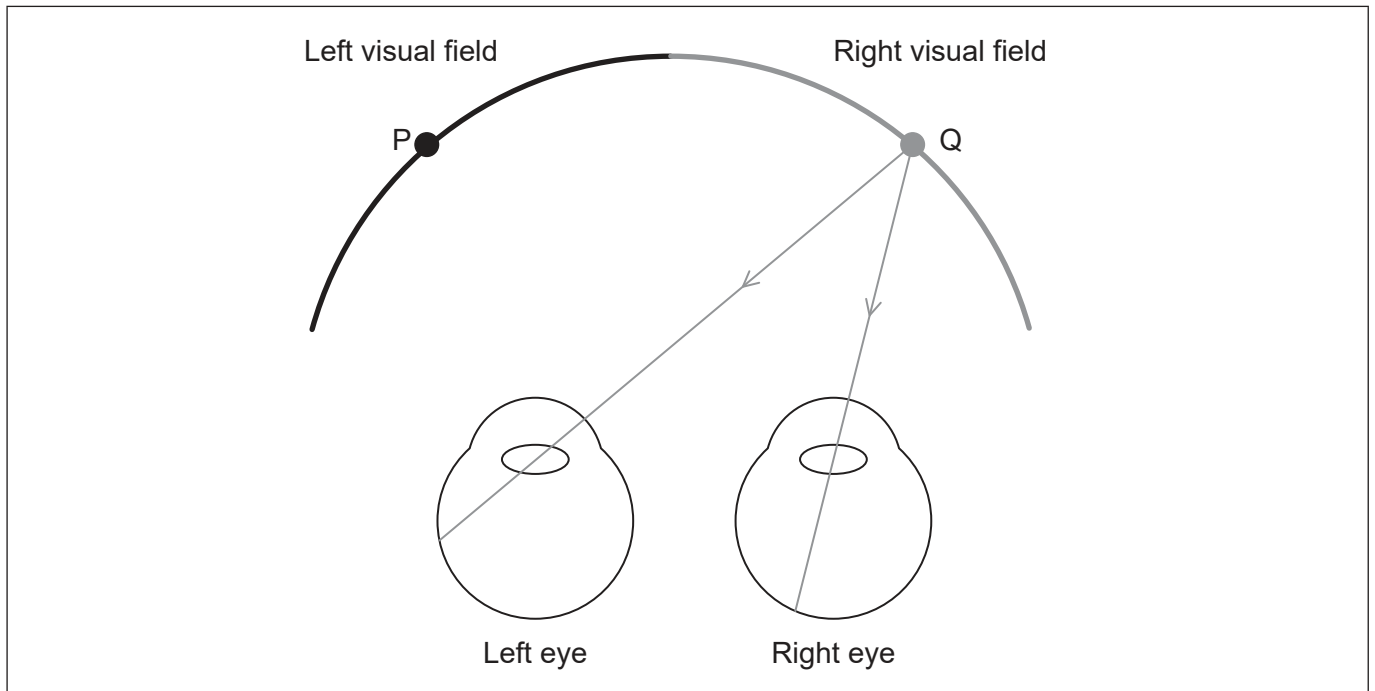

- (a) Draw a ray of light entering the left eye from point P. [1]
- (b) Information about the light from P entering the left eye is processed in the brain.
 - (i) State what region of the brain would process the information. [1]

.....

- (ii) State the side of the brain that would process the information. [1]

.....

- (c) State the type of cell in the retina which directly transmits impulses through the optic nerve to the brain. [1]

.....

(Option A continues on the following page)



32EP10

(Option A continued)

6. The hearing threshold is how loud a sound needs to be before an individual can perceive the sound. The chart shows the mean value of the hearing threshold for hearing-impaired individuals before and after receiving a cochlear implant. Normal human speech has a range of loudness of from 50 to 60 decibels (dB).

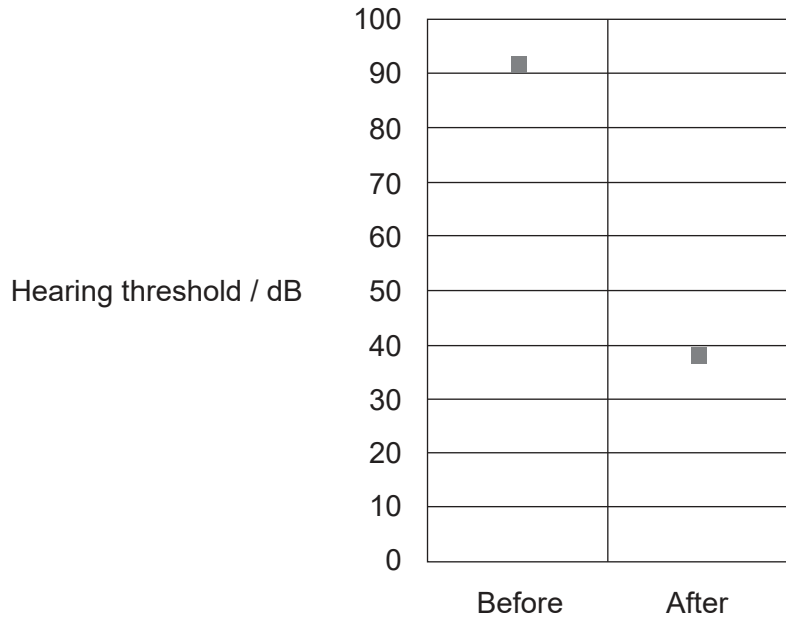

- (a) Outline the effect of the cochlear implant on hearing. [2]

.....

.....

.....

.....

- (b) Suggest, with reference to the structure of the ear, a reason that a cochlear implant requires an amplifier. [1]

.....

(Option A continues on the following page)



32EP11

Turn over

(Option A, question 6 continued)

(c) Describe the normal function of the cochlea.

[3]

.....

.....

.....

.....

.....

.....

.....

(Option A continues on the following page)



32EP12

(Option A continued)

7. Explain how autopsy and lesions can be used to identify the role of different brain parts. [4]

.....

.....

.....

.....

.....

.....

.....

.....

.....

.....

.....

.....

.....

.....

.....

End of Option A



32EP13

Turn over

Option B — Biotechnology and bioinformatics

8. The diagram shows an aerated fermenter commonly used in biotechnology.

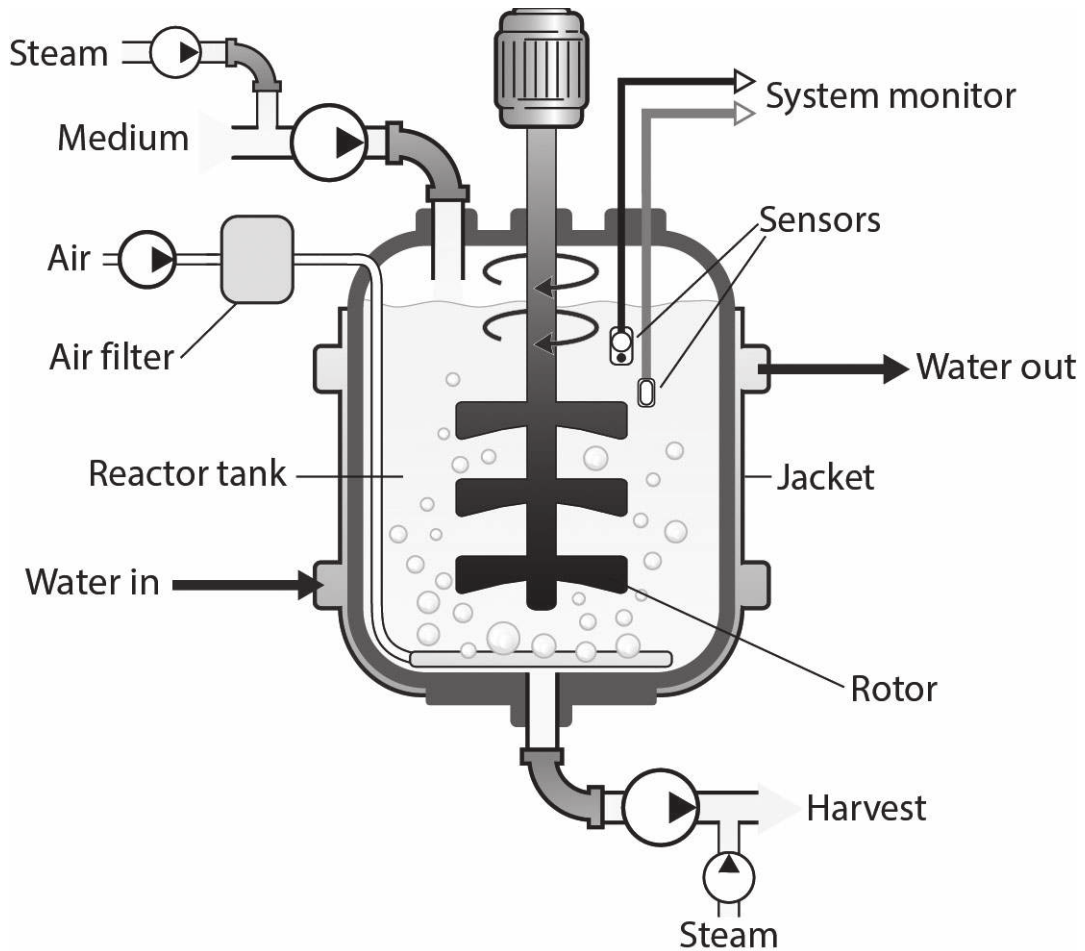

(a) Outline a reason for inserting steam into the fermenter before fermentation. [1]

.....

(b) Describe how optimal temperature is maintained inside the fermenter. [1]

.....
.....

(Option B continues on the following page)



32EP14

(Option B, question 8 continued)

(c) Explain how penicillin can be produced in a fermenter.

[3]

.....

.....

.....

.....

.....

.....

(Option B continues on the following page)



32EP15

Turn over

(Option B continued)

- 9. The chart shows the use of glyphosate and other herbicides on soybeans (*Glycine max*) grown in the US from 1998 to 2011. Also shown is the trend for the environmental impact quotient (EIQ) which is calculated from the toxicity of herbicides to wildlife and to humans, their persistence in the environment and their other ecological effects.

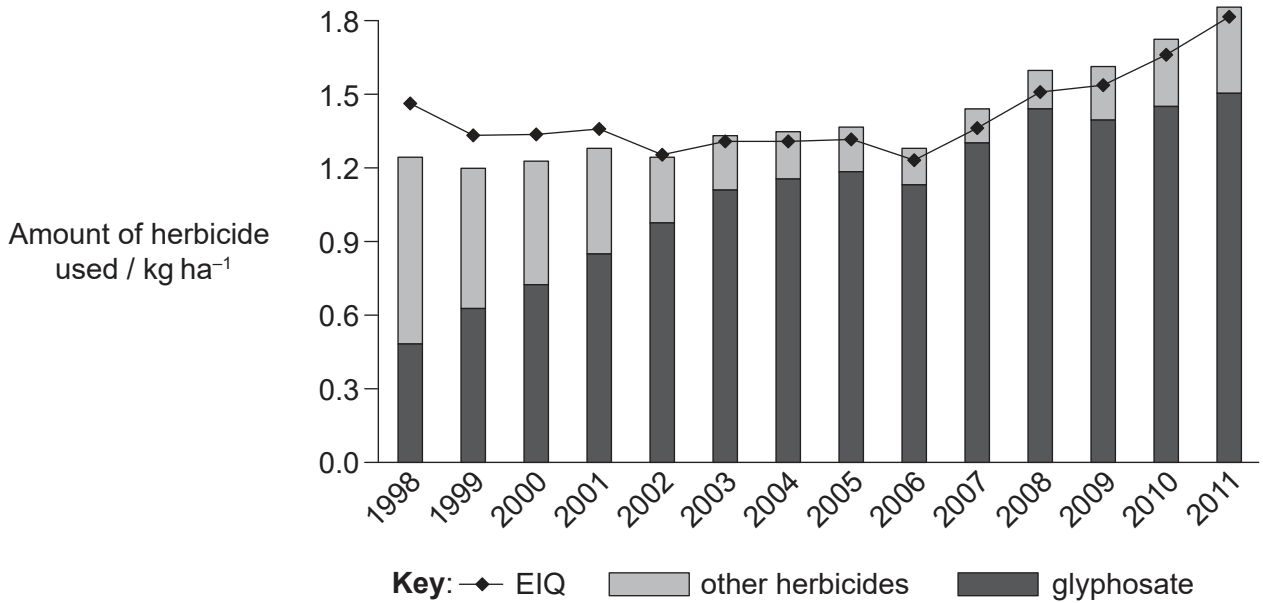

[Source: Reprinted with permission of AAAS from Perry, E.D., Ciliberto, F., Hennessy, D.A. and Moschini, G., 2016. Genetically engineered crops and pesticide use in U.S. maize and soybeans. *Science Advances*, [e-journal] 2(8). <https://doi.org/10.1126/sciadv.1600850>. © The Authors, some rights reserved; exclusive licensee American Association for the Advancement of Science. Distributed under a Creative Commons Attribution NonCommercial License 4.0 (CC BY-NC) <http://creativecommons.org/licenses/by-nc/4.0/> Readers may view, browse, and/or download material for temporary copying purposes only, provided these uses are for noncommercial personal purposes. Except as provided by law, this material may not be further reproduced, distributed, transmitted, modified, adapted, performed, displayed, published, or sold in whole or in part, without prior written permission from the publisher.]

- (a) State the year with the lowest EIQ for herbicides used in soybean growth in the US from 1998 to 2011. [1]

- (b) Using the data from 1998 to 2004, evaluate whether the use of glyphosate has a greater impact on the environment than other herbicides. [2]

(Option B continues on the following page)



(Option B, question 9 continued)

- (c) Explain the role of *Agrobacterium tumefaciens* in introducing glyphosate resistance into soybean crops. [3]

.....

.....

.....

.....

.....

.....

.....

.....

(Option B continues on the following page)



32EP17

Turn over

(Option B continued)

10. *Aequorea victoria* is a jellyfish that produces green fluorescent protein (GFP) which glows in blue light. The gene for GFP has been isolated and can be used as a marker gene. Plants with the gene incorporated glow when exposed to blue light.

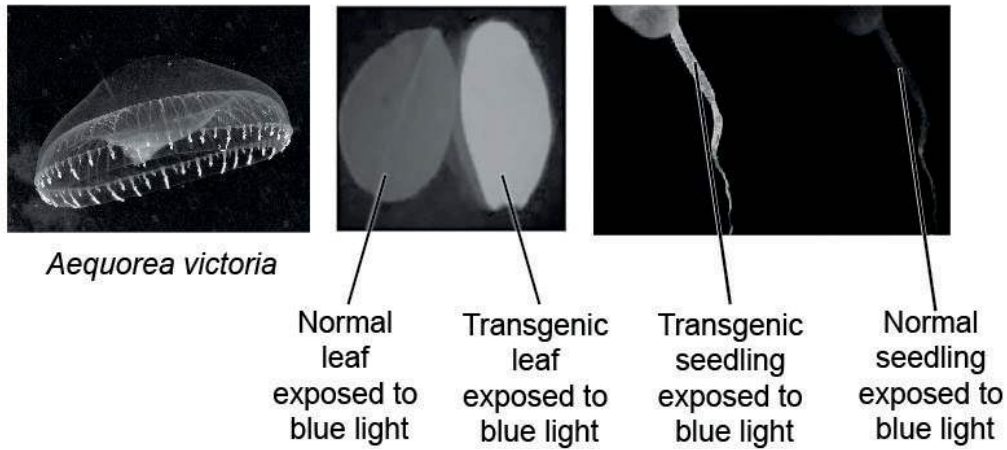

- (a) State the function of a marker gene. [1]

.....

.....

.....

- (b) Describe how genes are inserted into plants by electroporation. [2]

.....

.....

.....

- (c) Describe how an open reading frame (ORF) can be identified. [2]

.....

.....

.....

(Option B continues on the following page)



Option C — Ecology and conservation

12. Ecologists studied the distribution of five species of insectivorous wood warblers of the genus *Dendorica* living on different parts of coniferous trees in mature forests.

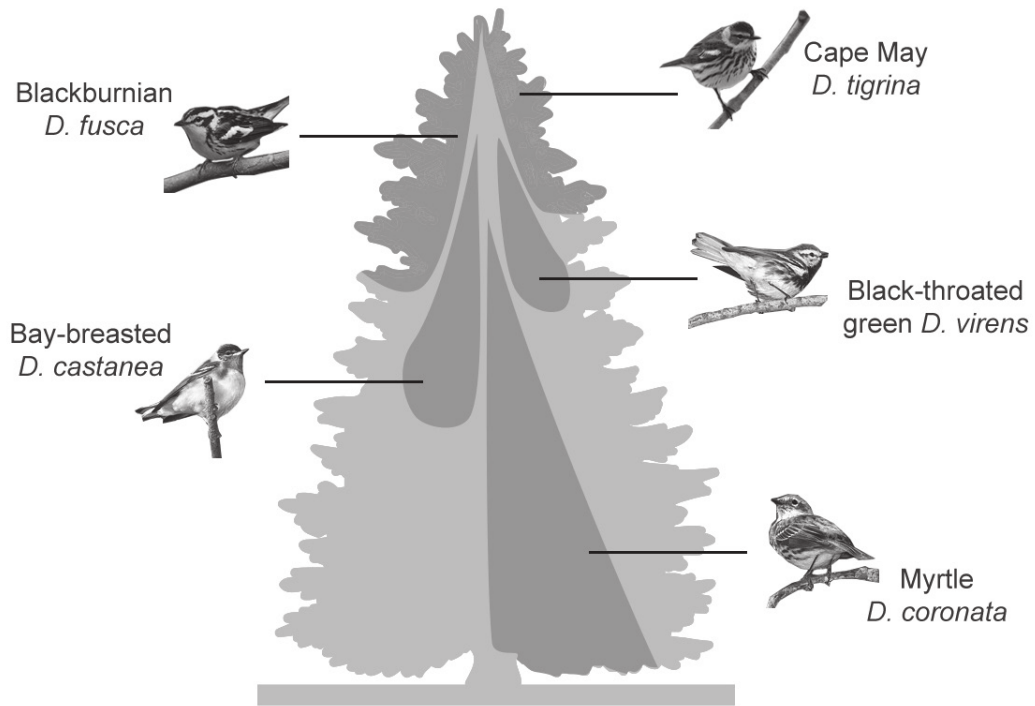

(a) Distinguish between the distribution of *D. tigrina* and that of *D. coronata*. [1]

.....
.....

(b) Outline the principle of competitive exclusion. [2]

.....
.....

(c) Other than position in the tree, suggest **two** ways in which the niches of the warblers in the ecosystem may differ. [2]

1:.....
2:.....

(Option C continues on the following page)



32EP20

(Option C, question 12 continued)

- (d) The diagram shows the realized niches of the five species of warbler. Suggest how the fundamental niche of *D. castanea* might differ from its realized niche. [2]

.....

.....

.....

.....

(Option C continues on the following page)



32EP21

Turn over

(Option C continued)

13. Plastic has accumulated in marine environments and is now causing problems for wildlife. Some marine birds have become entangled in plastic debris and some have been harmed by ingesting it. The table shows the extent of the problem worldwide in different groups of birds.

Group	Species	Number of species	Species with problems due to entanglement / %	Species with problems due to ingestion / %
A	penguins	16	38	6
B	grebes	20	10	0
C	albatrosses, petrels and shearwaters	99	10	63
D	pelicans, boobies, gannets, cormorants, frigatebirds and tropicbirds	51	22	16
E	skuas, gulls, terns and auks	122	18	33

(a) (i) Calculate the number of species of grebe with problems due to entanglement. [1]

.....

(ii) Suggest how entanglement in plastics can lead to the death of marine birds. [1]

.....

(b) (i) Identify the group with the greatest number of species with problems due to ingestion of plastics. [1]

.....

(ii) Describe how ingested plastics can cause problems to marine birds. [2]

.....

(Option C continues on the following page)



32EP22

(Option C continued)

14. The table shows the number of crabs found in two rockpools by the coast. There were 16 crabs in total in each rockpool.

Species	Pool A	Pool B
Brown crab (<i>Cancer pagurus</i>)	2	0
Common hermit crab (<i>Pagurus bernhardus</i>)	13	8
Small hermit crab (<i>Diogenes pugilator</i>)	0	8
Shore crab (<i>Carcinus maenas</i>)	1	0

(a) Two components of biodiversity are richness and evenness. Deduce which of the two pools was higher in

(i) richness [1]

.....

(ii) evenness. [1]

.....

(b) Calculation of Simpson's reciprocal diversity index for both rockpools gives the following results.

Pool	Simpson's reciprocal diversity index
A	1.5
B	2.1

Outline what conclusion can be drawn from the results. [1]

.....

.....

(Option C continues on the following page)



32EP23

Turn over

(Option C, question 14 continued)

- (c) The graph shows how the number of ant species found on isolated islands near New Guinea depends on the size of the island.

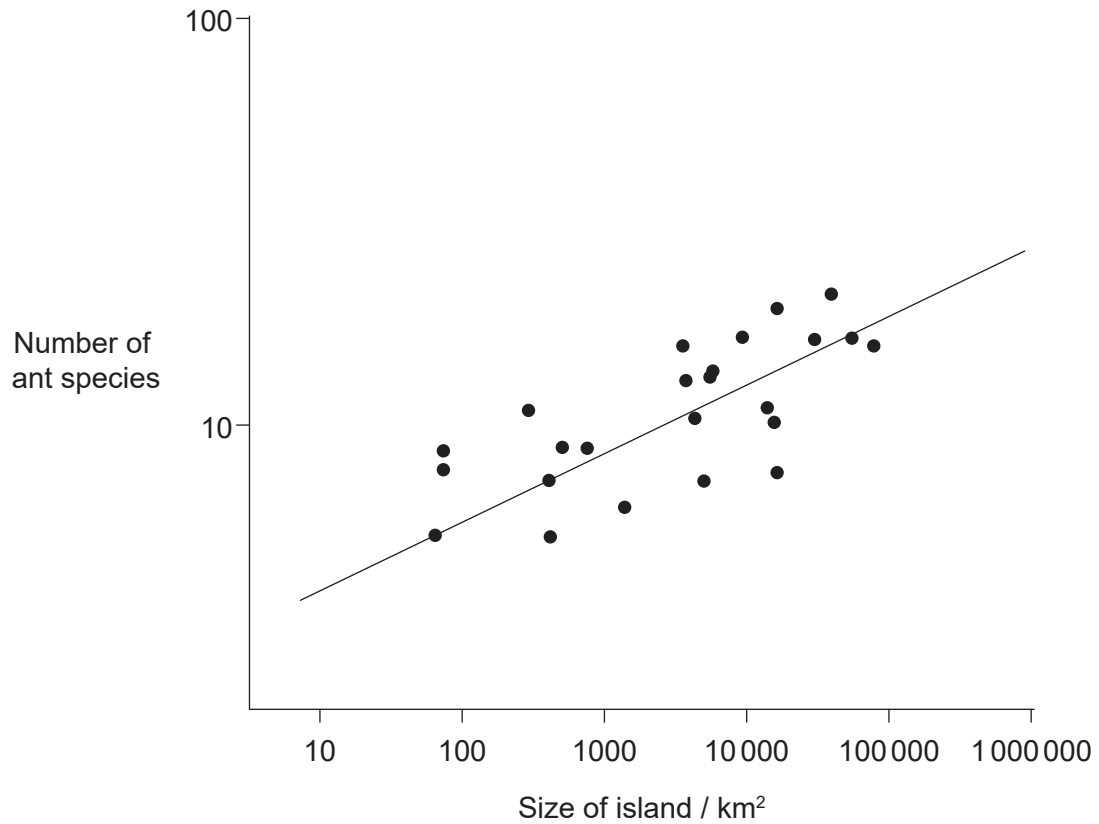

Explain the relationship between island size and number of ant species.

[1]

.....

.....

.....

.....

(Option C continues on the following page)



32EP24

(Option C continued)

15. Explain what information a pyramid of energy provides about an ecological community. [4]

.....

.....

.....

.....

.....

.....

.....

.....

.....

.....

.....

.....

.....

.....

.....

.....

.....

.....

.....

.....

.....

.....

End of Option C



32EP25

Turn over

Option D — Human physiology

16. The cladogram shows where mutations probably occurred in ancestral lines resulting in some animal species being unable to produce ascorbic acid (vitamin C).

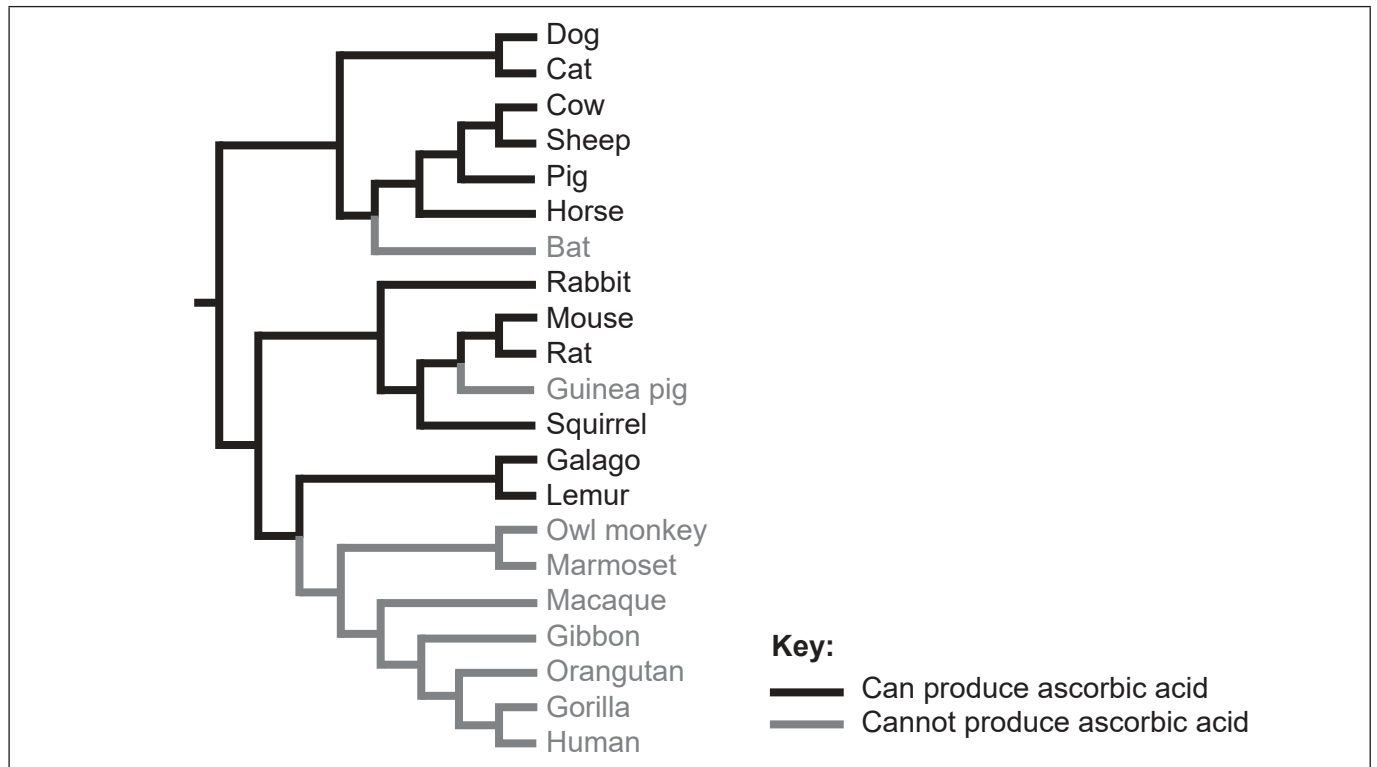

- (a) On the cladogram, label with an M, the point at which a mutation occurred, preventing the gibbon from synthesizing ascorbic acid. [1]
- (b) Outline the reason for ascorbic acid being described as an essential nutrient in the diet of humans. [1]

.....

.....

(Option D continues on the following page)



32EP26

(Option D, question 16 continued)

(c) A small box of orange juice contains these details on the side of the package:

Nutrition facts

Per 1 package (200 mL)

Nutrient	% Daily value
Fat	0 %
Sodium	1 %
Potassium	11 %
Protein	-
Vitamin C	80 %
Folate	25 %

Calculate the volume of juice needed to obtain the recommended daily requirement of vitamin C.

[1]

..... mL

(d) The apparatus used to measure energy content of food contains some water. Explain how this water is used when measuring the energy content of a food.

[2]

.....

(Option D continues on the following page)



32EP27

Turn over

(Option D continued)

17. (a) The table shows the origin and function of gastric secretions in the digestive system.

Secretion	Function	Secreting cells
.....	Stimulates secretion of HCl	Endocrine cells in gastric mucosa
HCl	Lowers pH in the stomach
Pepsin	Chief cells

Identify the missing items by completing the table. [3]

(b) Explain how *Helicobacter pylori* can cause stomach ulcers. [2]

.....

.....

.....

.....

.....

.....

.....

(Option D continues on the following page)



32EP28

(Option D continued)

18. The micrograph shows a section through part of the liver. The diagram illustrates the details of what is found within the marked area.

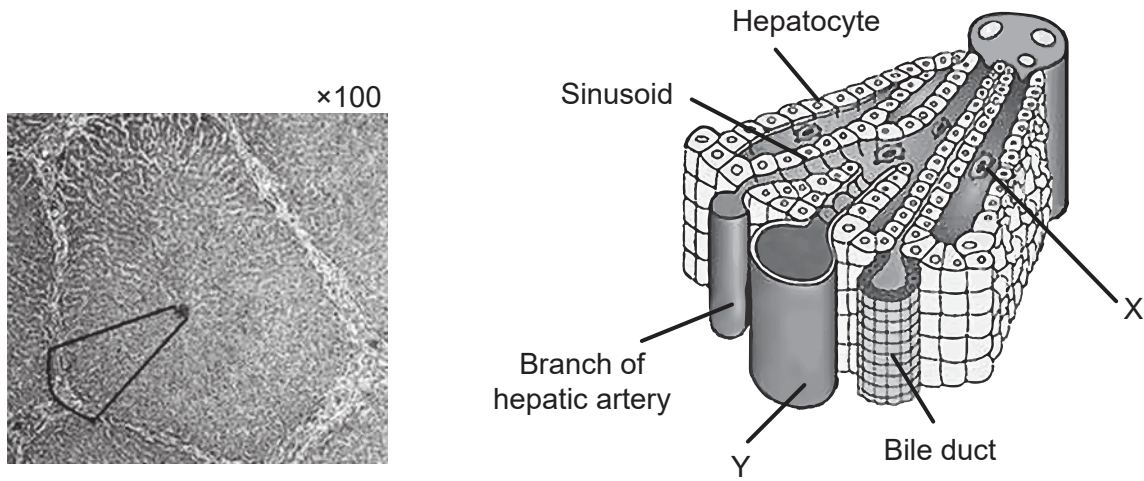

[Source: diagram on the right: Reprinted by permission from Springer Nature, *Nature Reviews Immunology*, "Aberrant homing of mucosal T cells and extra-intestinal manifestations of inflammatory bowel disease" by Adams and Eksteen ©2006.]

(a) Identify the

(i) phagocyte labelled X.

[1]

.....

(ii) blood vessel labelled Y which brings blood from the intestines.

[1]

.....

(b) Explain the function of hepatocytes in protein metabolism.

[2]

.....

.....

.....

.....

(Option D continues on the following page)



32EP29

Turn over

(Option D, question 18 continued)

(c) Compare and contrast the structure of sinusoids and capillaries.

[2]

.....

.....

.....

.....

(Option D continues on the following page)



32EP30

(Option D continued)

- 19. A radioactive tracer that accumulates in fibrin can be used to detect a recently formed thrombus. A scan shows where the tracer builds up, indicating thrombosis.

Removed for copyright reasons

Explain the causes and consequences of thrombosis.

[4]

.....

.....

.....

.....

.....

.....

.....

.....

.....

.....

.....

.....

.....

.....

.....

.....

.....

.....

.....

.....

.....

.....

End of Option D



32EP31

References:

2. [image: knife] © International Baccalaureate Organization 2020.
3. [diagram: photosynthesis] © International Baccalaureate Organization 2020.
- 3.(d) [chromatograph] Adapted from “Diversity of Photosynthetic Pigments” by Alexander F. Motten in *Tested Studies for Laboratory Teaching*, Volume 16 of the Association for Biology Laboratory Education and used by permission of the author.
6. [graph: hearing threshold] This article was published in *Brazilian Journal of Otorhinolaryngology*, Volume number 81, issue 2, Caixeta Guimarães, A., Machado de Carvalho, G., Duarte, A.S.M., Bianchini, W.A., Bravo Sarasty, A., di Gregorio, M.F., Zernotti, M.E., Sartorato, E.L., Menino Castilho, A., Hearing preservation and cochlear implants according to inner ear approach: multicentric evaluation., pp.190–196 , Copyright Elsevier (2015).
8. [diagram: aerated fermenter] Adapted from GYassineMrabetTalk, CC BY-SA 3.0 <https://creativecommons.org/licenses/by-sa/3.0>, via Wikimedia Commons.
9. [chart: use of glyphosate and other herbicides on soybeans] Reprinted with permission of AAAS from Perry, E.D., Ciliberto, F., Hennessy, D.A. and Moschini, G., 2016. Genetically engineered crops and pesticide use in U.S. maize and soybeans. *Science Advances*, [e-journal] 2(8). <https://doi.org/10.1126/sciadv.1600850>. © The Authors, some rights reserved; exclusive licensee American Association for the Advancement of Science. Distributed under a Creative Commons Attribution NonCommercial License 4.0 (CC BY-NC) <http://creativecommons.org/licenses/by-nc/4.0/> Readers may view, browse, and/or download material for temporary copying purposes only, provided these uses are for noncommercial personal purposes. Except as provided by law, this material may not be further reproduced, distributed, transmitted, modified, adapted, performed, displayed, published, or sold in whole or in part, without prior written permission from the publisher.
10. [jellyfish image] Sierra Blakely, Attribution, via Wikimedia Commons.

[leaves (middle image)] El-Shemy HA, Khalafalla MM, Ishimoto M. The role of green fluorescent protein (GFP) in transgenic plants to reduce gene silencing phenomena. *Curr Issues Mol Biol*. 2009;11 Suppl 1:i21–28. Epub 2009 Feb 2. PMID: 19193961.

[seedlings (right image)] Clark, David & Kim, Joo Young & Cho, Keun Ho & Colquhoun, Thomas. (2019). Strong Fluorescence Expression of ZsGreen1 in Petunia Flowers by *Agrobacterium tumefaciens*–mediated Transformation. *Journal of the American Society for Horticultural Science*. American Society for Horticultural Science. 144. 405–413. 10.21273/JASHS04776-19. <https://journals.ashs.org/jashs/view/journals/jashs/144/6/article-p405.xml>.
11. [trickle filter bed] © International Baccalaureate Organization 2020.
13. [table: plastic and wildlife] BIO Intelligence Service, 2011. *Plastic Waste in the Environment*. [pdf] European Commission. Available at: <http://ec.europa.eu/environment/waste/studies/pdf/plastics.pdf>.
14. [table: number of crabs] © International Baccalaureate Organization 2020.
- 14.(c) [graph: number of ant species] University of Windsor, *The Theory of Island Biogeography*. Available at: <http://web2.uwindsor.ca/courses/biology/macisaac/55-437/lecture9.htm>.
16. [cladogram] Drouin, G., Godin, J.-R. and Pagé, B., 2011. The Genetics of Vitamin C Loss in Vertebrates. *Current Genomics*, 12(5), pp.371–378.
- 16.(c) [nutrition facts for orange juice] © International Baccalaureate Organization 2020.
18. [micrograph] Micrograph of liver. https://undergraduate.vetmed.wsu.edu/courses/vph-308/histology/lab-1-histology-cells-and-organelles/liver-slide-wsu_2_052 courtesy of Patrick D. Wilson, MS, DVM, Clinical Associate Professor, Veterinary Integrative Biosciences, College of Veterinary Medicine & Biosciences, Texas A&M University.

[diagram] Reprinted by permission from Springer Nature, *Nature Reviews Immunology*, “Aberrant homing of mucosal T cells and extra-intestinal manifestations of inflammatory bowel disease” by Adams and Eksteen ©2006.



32EP32